

# SPECIFICATIONS

## MEASUREMENTS

Lamps	LED Modules 4 x 230 W
Generator	3.5 kW Inverter
Engine	Champion 196cc Gasoline
Receptacles	One GFI duplex 20 A / 120 V
Fuel capacity	17.5 gal (66.2 L)
Wheel size	13 in (33 cm)
Axle rating	2,200 lbs (997 kg)
Tongue weight travel position	199 lbs (90 kg)
Total weight no fuel	1,005 lbs (456 kg)

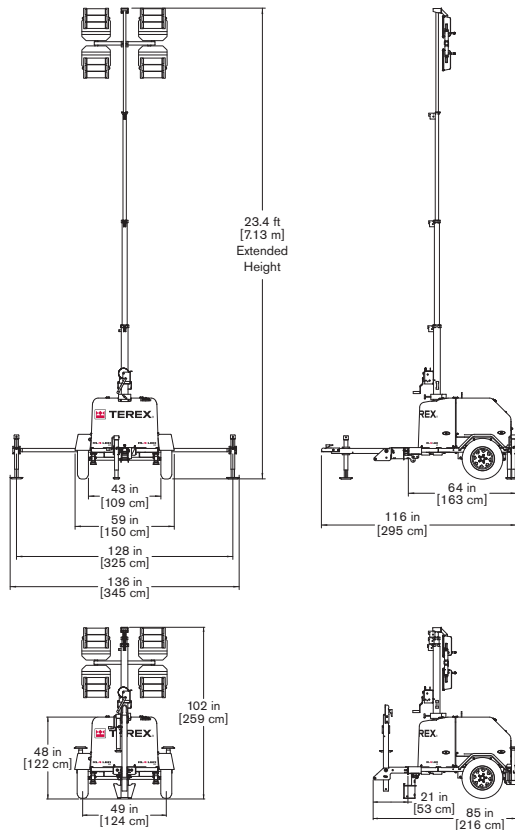

## FEATURES

Durable 23.4 ft / 7.13 m vertical mast with manual self braking winch, mast brake, and 359 degree mast rotation for quick setup and light positioning

4 x 230 W LED Modules, Champion 3.5 kW Inverter Generator, 17.5 gallon fuel tank provide up to 80 hours of run time

Efficient design layout allows up to 17 units per truckload, with fork pockets and lifting eye for quick loading and unloading

Rust proof polymer covers provides ample access for service and maintenance, with locking tabs for security

Platform to access LED Modules and fold up tongue for transport

DOT approved run, stop, and turn lights standard

120V AC Power < 3% THD

## RL™4 LED GAS LIGHT TOWER



## CHASSIS OPTIONS

Genie® branding and blue covers

Dome light with switch, 12V

Export racking and preparation

Multiple hitch configurations

## ENGINE OPTIONS

3.5 KW Champion Inverter

## TOWER OPTIONS

4 horizontally mounted LED Modules



WORKS FOR YOU.™

[www.genielift.com](http://www.genielift.com)

Effective Date: January, 2019. Product specifications and prices are subject to change without notice or obligation. The photographs and/or drawings in this document are for illustrative purposes only. Refer to the appropriate Operator's Manual for instructions on the proper use of this equipment. Failure to follow the appropriate Operator's Manual when using our equipment or to otherwise act irresponsibly may result in serious injury or death. The only warranty applicable to our equipment is the standard written warranty applicable to the particular product and sale and we make no other warranty, express or implied. Products and services listed may be trademarks, service marks or trade names of Terex Corporation and/or their subsidiaries in the USA and many other countries. Terex, Genie and Works For You are trademarks owned or licensed by Terex Corporation or its subsidiaries. All other trademarks are property of their respective owners. © 2019 Terex Aerial Work Platforms. RL4 0210F Part #109044

Genie United States  
6464 185th Ave. NE  
Redmond, WA 98052  
Telephone +1 (425) 881-1800  
Toll Free in USA/Canada +1 (800)-536-1800  
Fax +1 (425) 883-3475

Distributed By:



**WORKS FOR YOU.**