

SPECIFICATIONS

MEASUREMENTS

Lamps	Metal halide 4 x 1,000 W
Generator	Brushless 60 Hz, 6.0 kW
Engine	Kubota® diesel 13.6 hp
Receptacles	One GFI duplex 20 A / 120 V One T/L 30 A / 240 V
Fuel capacity	30 gal (114 L)
Wheel size	15 in (38 cm)
Axle rating	3,500 lbs (1,558 kg)
Tongue weight travel position	147 lbs (67 kg)
Total weight no fuel	1,950 lbs (885 kg)

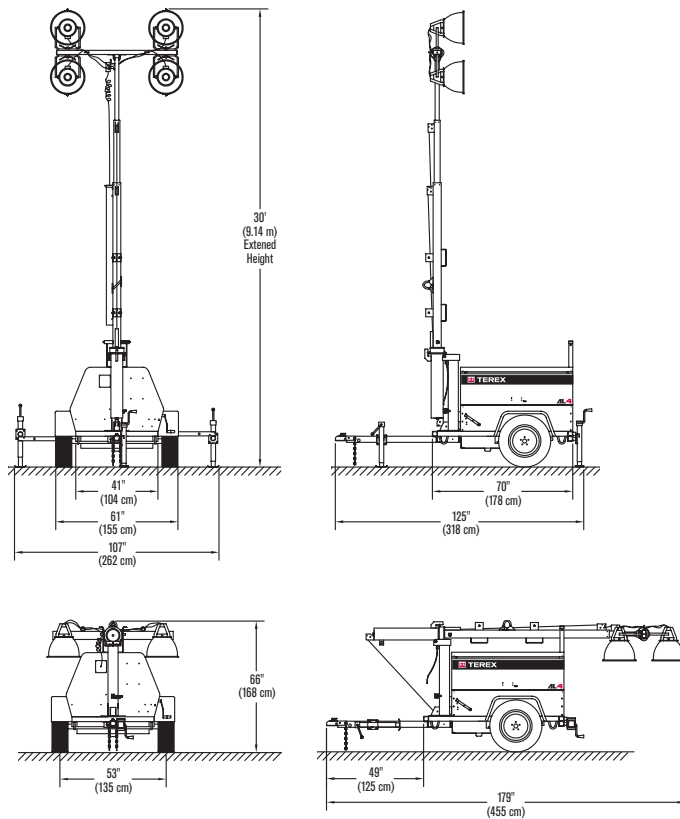

Notice: Metal halide lamp bulbs contain mercury (Hg). Dispose of lamp bulbs according to local, state and federal laws.

FEATURES

4 X 1000 W metal halide lights with Kubota engine and 6kW generator which provides quiet 71 dBA at 23 feet and fuel efficient 60 hour run time.

Durable 30' fully galvanized mast with single self-braking winch design, 359 degree rotation, and retractable mast cable gives excellent illumination at long distances.

Standard engine protection includes high water temperature and low oil auto shutdowns.

Quick disconnect lights and ballasts allow for easy troubleshooting, service, and repair.

Standard DOT approved run, stop and turn lights

Heavy duty mast, chassis, and 3,500 lbs rated axle to handle rough road towing.

Highway safety chains with snap hook

AL™4 LIGHT TOWER



CHASSIS OPTIONS

30 gal fuel tank w/ spill containment	Hitch, combination ring and ball
50 gal fuel tank	Spare tire and wheel
Dome light with switch, 12V	Tough coat paint surface: cabinet and trailer front
Export racking and preparation	Trailer brakes, electric
Hitch, 2 1/2 in. ring	Trailer brakes, Hydraulic surge: must specify ring or ball hitch
Hitch, 2 5/16 in. ball	

ENGINE OPTIONS

6 kW, 60 Hz, generator with 15.3 hp Perkins® diesel	8 kW, 60 Hz, generator with 13.6 hp Kubota® diesel
7 kW, 50 Hz, generator with 13.6 hp Kubota® diesel	Automatic air shutdown
	Fuel/water separator filter
	Fuel/water separator with fuel line heater

TOWER OPTIONS

4 horizontally mounted lights, cast aluminum square housing
Electric winch

COLD WEATHER OPTIONS

Cold weather package including: 700 CCA battery, battery heater blanket, engine block heater and low temperature coolant (-40F)



WORKS FOR YOU.™

www.genielift.com

Effective Date: January, 2019. Product specifications and prices are subject to change without notice or obligation. The photographs and/or drawings in this document are for illustrative purposes only. Refer to the appropriate Operator's Manual for instructions on the proper use of this equipment. Failure to follow the appropriate Operator's Manual when using our equipment or to otherwise act irresponsibly may result in serious injury or death. The only warranty applicable to our equipment is the standard written warranty applicable to the particular product and sale and we make no other warranty, express or implied. Products and services listed may be trademarks, service marks or trade names of Terex Corporation and/or their subsidiaries in the USA and many other countries. Terex, Genie and Works For You are trademarks owned or licensed by Terex Corporation or its subsidiaries. All other trademarks are property of their respective owners. © 2019 Terex Aerial Work Platforms. AL4 0210G Part #109045

Genie United States
6464 185th Ave. NE
Redmond, WA 98052
Telephone +1 (425) 881-1800
Toll Free in USA/Canada +1 (800)-536-1800
Fax +1 (425) 883-3475

Distributed By:



WORKS FOR YOU.™